

<b>Informazioni marcatura / Marking information / Informations certification / Prüfungsinformation / Información de marcado</b>	 <b>EN 14785:2006</b>		
Ente Notificato / Notified Body / Institut notifié / Benanntes Labor / Entidad autorizada	TÜV Rheinland Energy GmbH - NB 2456		
Rapporto di prova / Test Report / Epreure d'essai / Prüfbericht / Informe de Prueba	K32662022T1	29/06/2022	

Dati tecnici di funzionamento / Functioning Technical datas / Données techniques de fonctionnement / Technische Merkmale für den Betrieb / Datos técnicos de funcionamiento				
Peso netto / Net weight / Poids net / Nettogewicht / Peso neto		101		kg
Capacità totale serbatoio / Feed box total capacity / Capacité totale réservoir / Tank-Gesamtkapazität / Capacidad total depósito		~ 15		kg
Tensione nominale / Rated voltage / Tension nominale / Nennspannung / Tensión nominal		230		V
Frequenza nominale / Rated frequency / Fréquence nominale / Nennfrequenz / Frecuencia nominal		50		Hz
Potenza elettrica nominale / Rated input power / Puissance électrique nominale / Elektrische Leistungsaufnahme / Potencia eléctrica nominal		400,0		W
Volume di riscaldamento max. / Max. heating volume / Volume de réchauffement max. / Max. Heizvolumen / Volumen de calefacción máx. / (30 Kcal/h x m <sup>3</sup> )		230		m <sup>3</sup>
Prevalenza pompa / Pump head / Prévalence pompe / Förderhöhe Pumpe / Altura total de elevación de la bomba		-		m
Contenuto fluido scambiatore / Fluid contents of the exchanger / Liquide contenu dans l'échangeur / Gehalt Flüssigkeit im Ausstauscher / Contenido fluido intercambiador		-		L
Massima pressione di esercizio / Maximun working pressure / Puissance d'exercice max / Max Betriebsdruck / Máxima presión de trabajo		-		bar
Dati di omologazione / Certification datas / Données de certification / Daten der Zulassung / Datos de homologación		Min	Max	
Potenza termica globale (introdotta) / Global thermal power (Heat input) / Puissance thermique globale / Brennstoffwärmeleistung / Potencia térmica total		3,4	8,8	kW
Potenza termica nominale (utile) / Nominal thermal power (Heat output) / Puissance thermique nominale / Nennwärmeleistung / Potencia térmica nominal		3,2	8,0	kW
Potenza resa all'aria / Power given back to air / Puissance rendue à l'air / Raumwärmeleistung / Potencia suministrada al aire		3,2	8,0	kW
Potenza resa all'acqua / Power given back to water / Puissance rendue à l'eau / Wasserwärmeleistung / Potencia suministrada al líquido		0,0	0,0	kW
Consumo orario / Hourly consumption / Consommation horaire / Stundenverbrauch / Consumo horario		0,7	1,8	kg/h
Rendimento / Efficiency / Rendement / Wirkungsgrad / Rendimiento		92,4	91,1	%
Emissione media CO <sub>2</sub> / Mean CO <sub>2</sub> emission / Emission moyenne CO <sub>2</sub> / Durchschn CO <sub>2</sub> Emission / Emisión media CO <sub>2</sub>		8,1	14,0	%
Emissione media CO / Mean CO emission / Emission moyenne CO / Durchschn CO Emission / Emisión media CO	(13% O <sub>2</sub> )	229,0	119,0	mg/m <sup>3</sup>
		151,0	79,0	mg/MJ
Emissione media NO <sub>x</sub> / Mean NO <sub>x</sub> emission / Emission moyenne NO <sub>x</sub> / Durchschn NO <sub>x</sub> Emission / Emisión media NO <sub>x</sub>	(13% O <sub>2</sub> )	98,0	90,0	mg/m <sup>3</sup>
		65,0	60,0	mg/MJ
Emissione media OGC / Mean OGC emission / Emission moyenne OGC / Durchschn OGC Emission / Emisión media OGC	(13% O <sub>2</sub> )	4,0	2,0	mg/m <sup>3</sup>
		3,0	1,0	mg/MJ
Emissione media polveri / Mean dust emission / Emission moyenne poudres / Durchschn Staub Emission / Emisión media polvos	(13% O <sub>2</sub> )	15,0	14,9	mg/m <sup>3</sup>
		10,0	10,0	mg/MJ
Temperatura media fumi / Mean flue gas temperature / Température moyenne des fumees / Durchschn Abgastemperatur / Temperatura media humos		107,0	177,9	°C
Flusso gas coml -1bil(e)/(F)17(lue gasmassn mo)7w er)5(a)4(t)6(e)/(F)17(lxe gzs c)6(oml -1bl(e /Bry)10(en ga flsse /(F)17(ljso gas c)6(oml -1bles))TJ-2.567 0 Td(29)Tj4.961 inse / Temperatura media d humo pauradl cterl ye imenssioamienat				

Condotto aspirazione aria / Air intake pipe / Conduit aspiration air / Zuluftansaugleitung / Conducto de aspiración de aire	<b>A</b>	50	Ø mm
Condotto espulsione fumi / Flue gas exhaust pipe / Conduit expulsion fumées / Rauchabzugsleitung / Conducto de expulsión de humos	<b>B</b>	80	Ø mm
Canalizzazione aria calda / Hot air ducting system / Canalisation / Kanalisierung / Canalizacion de aire	<b>F</b>	-	Ø mm
Scarico sicurezza 3 bar / 3 bar safety drain / Décharge sécurité 3 bar / Sicherheitsauslass 3 Bar / Descarga de seguridad 3 bar	<b>T1</b>	-	"
Mandata/uscita caldaia / Boiler flow outlet / Aller/sortier chaudiere / Kessel - vorlauf/ausgang / Ida/salida de la caldera	<b>T2</b>	-	"
Ritorno/ingresso caldaia / Boiler return/inlet / Retour/entree chaudiere / Kessel - rücklauf/eingang / Retorno/entrada de la caldera	<b>T3</b>	-	"
Attacchi scambiatore di sicurezza DSA / DSA safety heat exchanger connections / Raccords échangeur de sécurité DSA / Anschlüsse sicherheitswärmetauscher DSA / Conexiones intercambiador de seguridad DSA	<b>T4 - T5</b>	-	"

498

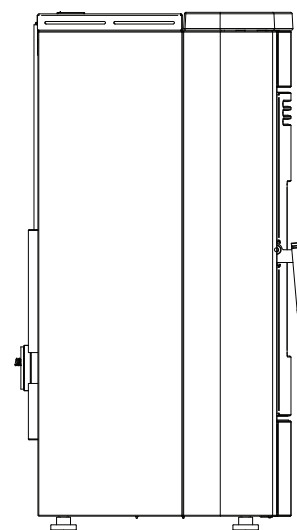
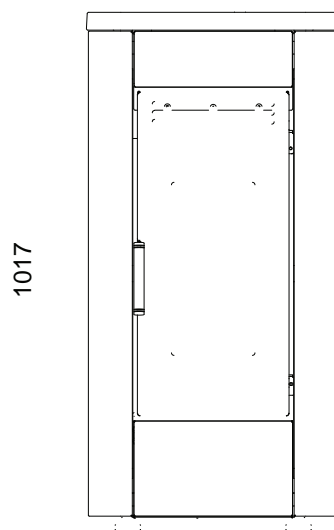

12 535 29

575

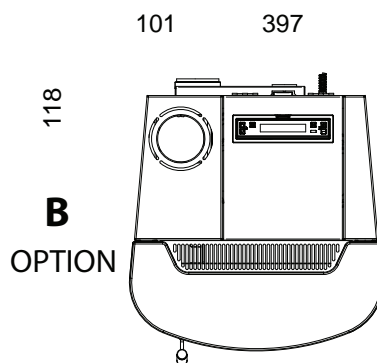

**B**

OPTION

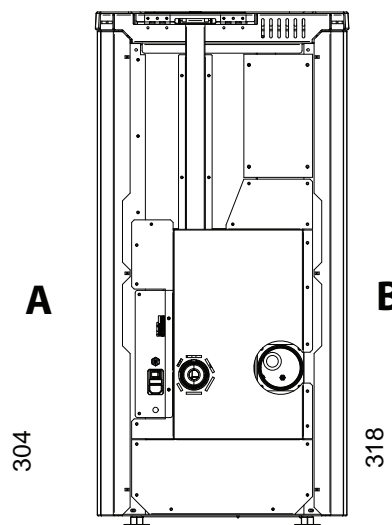

**A**

**B**

194 305

364 134

A= Ø 48mm  
B= Ø 80mm

